

Bare Branches

FABRICS BY LONNI ROSSI



Moon Circles Designed by:
Lonni Rossi

Quilt Size: **24" x 80"**

andoverfabrics.com

Bare Branches

It all started with a branch! I spotted this very interesting branch laying on the ground and took it back to the studio. I scanned the branch into the computer and the magic started to happen — and the basic motifs for "Bare Branches" emerged.

I imagined warm colors of fall mingled with pristine icy stillness of early snowfall. "Bare Branches" has a range of values from very light to very dark, with many gradations in between. — *Lonni Rossi*

andover



makower uk
The Henley Studio

Free Pattern Download Available

1384 Broadway New York, NY 10018
Tel. (800) 223-5678 • andoverfabrics.com

2/5/03

Moon Circles



Introducing Andover Fabrics new collection: **BARE BRANCHES** by LONNI ROSSI

Quilt designed by Lonni Rossi

Quilt finishes 24" x 90"

Is it a bed scarf, table runner, or skinny wall quilt? Use it however you please, and this easy-to-make quilt will work hard for you. The luscious botanical prints come in two stunning colorways—one with teals and soft neutrals, the other with black and sand and rust.

Cutting Directions

Note: Read assembly directions before cutting patches. All measurements are cut sizes and include ¼" seam allowances. A fat ¼ is a 9" x 20"-22" cut of fabric. WOF designates the width of fabric from selvedge to selvedge (approximately 42" wide).

Fabric A

Cut (1) panel 25" x 79"

Fabric B

Cut (4) circles with 20" diameter
(see Step 1)

Cut (1) half-circle with 20" diameter

Fabric C

Cut (2) rectangles 7" x 25"

Fabric D

Cut (12) strips 1" x WOF (see Step 2)

Fabrics E, F, G

From each: Cut (4) squares 3" x 3"
(see Step 3)

Fabric H

Cut (6) strips 3½" x WOF for
invisible binding (see Step 9)

Cut (2) squares 3" x 3"

Backing

Cut (1) panel 32" x 98"

Fabric Requirements

		Yardage	Teal	Brown
Fabric A	background	2½ yards	7530-MT	7530-MK
Fabric B	moons	1½ yards	7533-MTN	7533-MKR
Fabric C	setting	½ yard	7531-MTL	7531-MKR
Fabric D	strips	½ yard	7532-MTN	7532-MK
Fabric E	squares	fat ¼ yard	7534-MT	7534-MKR
Fabric F	squares	fat ¼ yard	7534-MTN	7534-MK
Fabric G	squares	fat ¼ yard	7535-MT	7535-MKN
*Fabric H	squares	¾ yard	5468-T	5468-DK
Backing		2¾ yards	5468-T	5468-DK

*includes "invisible" binding

Making the Quilt

1. Draw 4 circles with 20" diameter and 1 half-circle onto the paper side of paper-backed fusible web. Cut out circles ¼" away from drawn lines. Following manufacturer's instructions, fuse circles to the wrong side of Fabric B. Cut out circles on the drawn lines. Trim about 9" off one side of 3 of the complete circles. Set aside.
2. Cut a piece of fusible web 40" x 18". Fuse to the wrong side of Fabric D. Cut 12 strips each 1" wide and 40" long. Set strips and the remainder of fused fabric aside.
3. Press fusible web to the wrong side of Fabrics E-H. Cut out 3" squares as listed. Set aside.
4. Position the circles on the Fabric A background panel as shown in the quilt photograph. Place the half-circle at the bottom of the panel, aligned with the raw edge. Fuse circles in place.
5. Referring to the quilt photo for relative lengths, cut the Fabric D strips into 26 rectangles of assorted lengths. Feel free to cut rectangles the lengths that you think look best. Fuse rectangles to the quilt. The ends of some strips should be even with the top and bottom edges of the background. If you run out of strips, cut more from the leftover in Step 2.
6. Fuse the 3" squares in position on the quilt top following the quilt photo.
7. Sew Fabric C rectangles to the top and bottom.

Finishing the Quilt

8. Layer the quilt with batting and backing and baste. Using a walking foot, start by quilting all the vertical straight lines on the narrow fused strips over the circles. Quilt all around the edge of each fused square. Quilt in the ditch at the seam between the Fabric A panel and the Fabric C ends. Quilt straight vertical lines on the Fabric C patches using the printed branches as your guide. Starting at the vertical center of the runner, quilt straight lines ½" apart across the background fabric, but not in the circles.

Moon Circles

Invisible Binding

These directions are for binding that doesn't show on the front of the quilt. Strips of fabric are stitched around the quilt to make a facing with mitered corners. The entire facing is turned to the back of the quilt. These directions work for any quilt when you want the design to be uninterrupted all the way to the edge of the quilt.

Step 1

When you have finished quilting, trim the edges of the quilt so all sides are straight and the corners are square.

Step 2

Measure through the center of your quilt from the top raw edge to the bottom raw edge. Note this measurement. It will be the length of your side strips. Similarly, measure from side to side across the center of the quilt. This will be the length of your top and bottom strips. Cut the number of 3½"-wide strips needed to construct the facing strips. Piece them with diagonal seams as necessary to make 2 side strips and 2 top/bottom strips the exact length needed for your quilt.

Step 3

Press ½" to the wrong side on one long edge of each strip.

Step 4

Lay quilt face up on a table. Right sides together, align the unpressed edge of one strip with the corresponding edge of the quilt top, matching centers. Starting at the center, pin the binding to the quilt to within 6 inches of each corner. Continue in this manner until you have pinned the binding strips to all four edges of the quilt top.

Step 5

Using a 45° triangle ruler, mark the sewing line for the miter at the end of each strip, remembering to add the seam allowance. With right sides together, pin corners and sew the miters without removing the pinned binding from the quilt. Trim off the excess fabric, leaving a ¼" seam allowance.

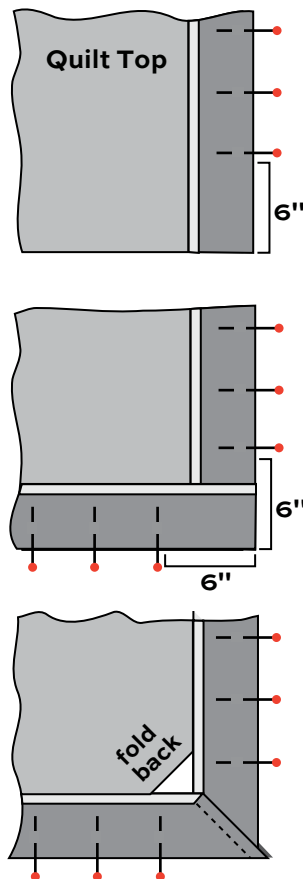

Step 6

Finger press the seam allowances open and finish pinning the corners to the quilt. Using a walking foot, sew the binding to the quilt using a ⅜" seam all the way around all four sides. Trim the seam allowances at the corners.

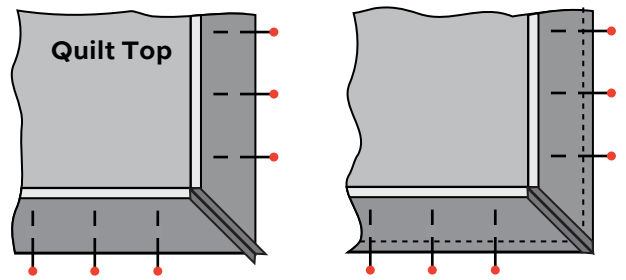

Step 7

Turn the binding to the back of the quilt, making sure the corners are fully turned to a nice crisp point.

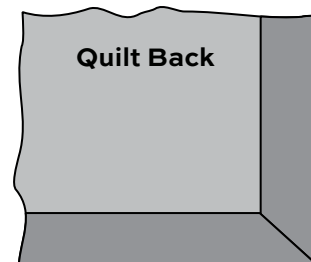

Step 8

Steam press so the edge is straight and the quilt lies flat. Whip stitch the folded edge to back of quilt by hand, being careful not to let any stitches show through to the front of the quilt.

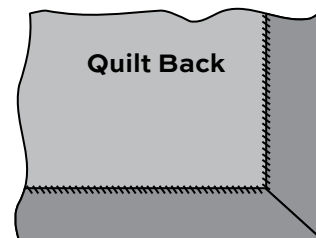

Bare Branches

FABRICS BY LONNI ROSSI



7530-MT*



7531-MTL*



7532-MTN*



7533-MTN*



7534-MT*



7534-MTN*



7535-MT*



7530-MK



7531-MKR



7532-MK



7533-MKR



7534-MK



7534-MKR



7535-MKN

Blend with fabrics from **Raindrops** by Lonni Rossi



5468-C

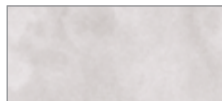

5468-C1



5468-DK

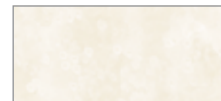

5468-L



5468-LT



5468-N



5468-N3



5468-O



5468-R



5468-T*

Blend with **Andover Solids**



A-S-L



ANB-BLACK

*Indicates fabrics used in featured quilt pattern. Fabrics shown are 25% of actual size.

andover

makower uk
The Henley Studio

Free Pattern Download Available

1384 Broadway New York, NY 10018
Tel. (800) 223-5678 • andoverfabrics.com